

ATTACHMENT DRAWINGS HAVE BEEN INCLUDED AS SUGGESTED INSTALLATION DETAILS ONLY; ALL ATTACHMENTS, STEEL SIZES, GAUGE THICKNESS, AND ANCHOR SIZES SHOULD BE CALCULATED BY A STRUCTURAL ENGINEER; STONE LEGENDS IS NOT LIABLE FOR INSTALLATION OF ANY

STRAP WITH
SCREWS

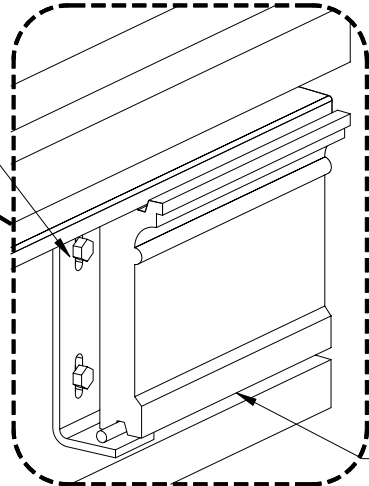

BANDING

STRAP WITH
SCREWS

CLIP WITH SCREWS

LAG BOLT

ANGLE IRON LINTEL
W/WELDED ROD

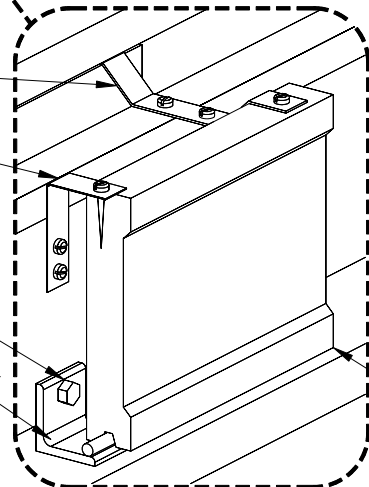

BANDING

① ATTACHMENT OF BANDING TO WOOD TYPE STRUCTURE WITH LINTEL & ROD & STRAP & SCREW & LAG BOLT

N.T.S.