

**Cutting Details dwg. Top of Step Handrail: 1) Easing Over Tangents 2) Miter Cut Details**

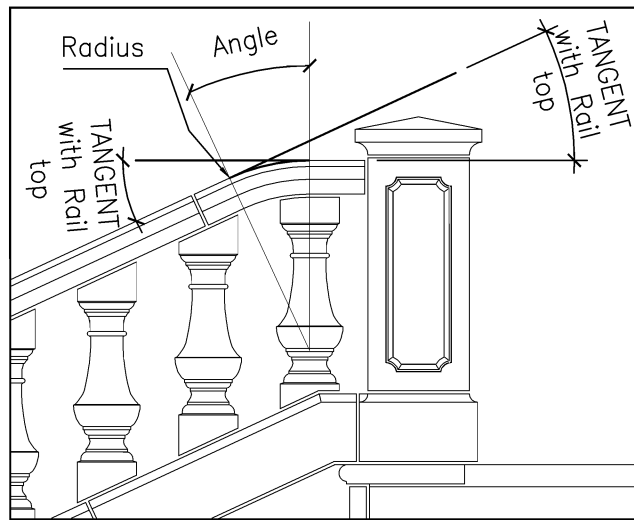

1 Easing Over Handrail Tangent Detail

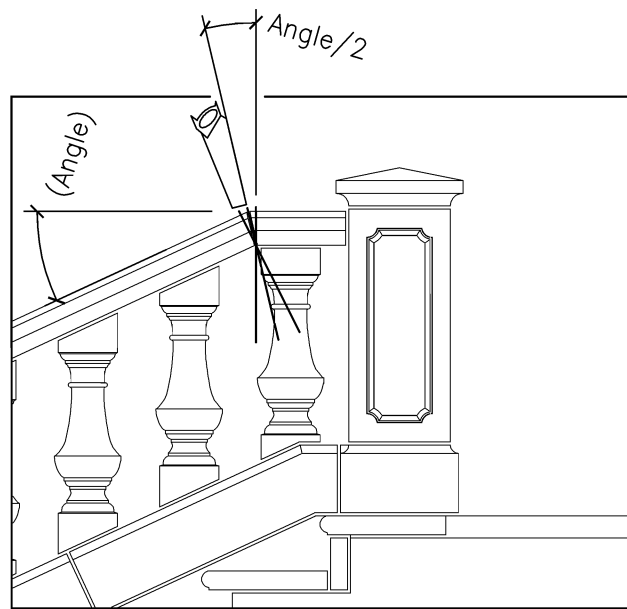

2 Mitered Handrail Cutting Detail

<input type="checkbox"/>	Type Drawing
<input type="checkbox"/>	Interface/Attachments
<input type="checkbox"/>	Finishing Details
<input checked="" type="checkbox"/>	Flashing
<input checked="" type="checkbox"/>	Cutting Details
<input checked="" type="checkbox"/>	Building Code
<input checked="" type="checkbox"/>	Measuring & Dimensional Drawings
<input type="checkbox"/>	Attached to type structure

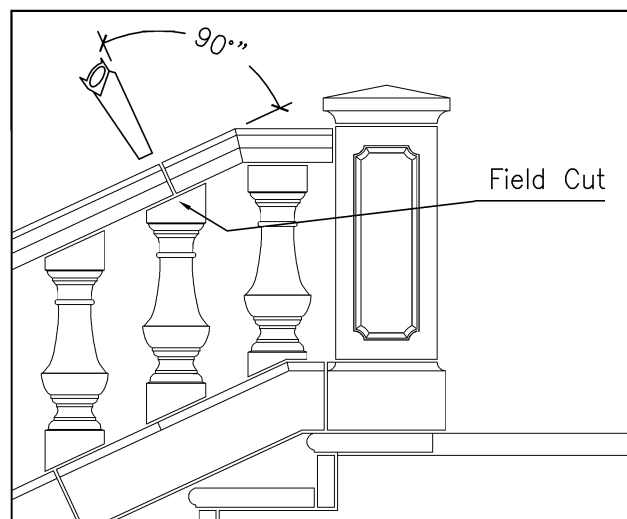

3 Beveled Handrail Cutting Detail

SCALE: NTS.

DEVELOPMENT DRAWING	TITLE: <b>Cutting Details dwg. Top of Step Handrail:</b>
DRAWING DETAIL: <b>MULTIVIEWS</b>	
DESCRIPTION: <b>Steps &amp; Balustrades</b>	
NOTES:	
	DATE:
	DRAWING #: <b>BALFIN REV:</b>

**Design Options dwg. Balustrade Top of Stair Handrail:** 1) Miter Cut  
 2) Solid Bevel  
 3) Easing Over

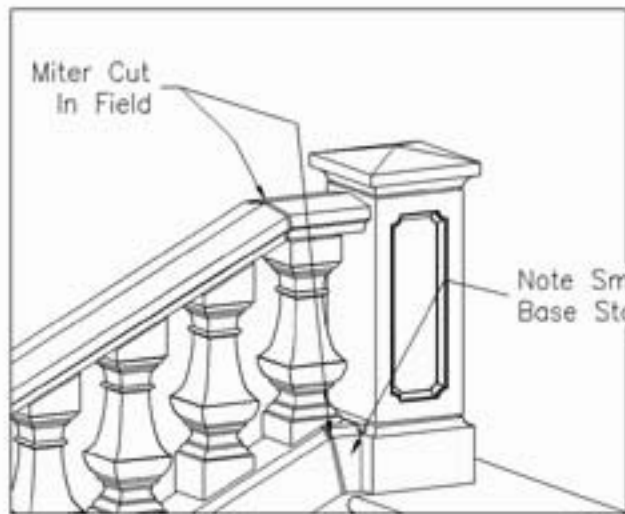

① Mitered Handrail  
 Standard Miter Cut

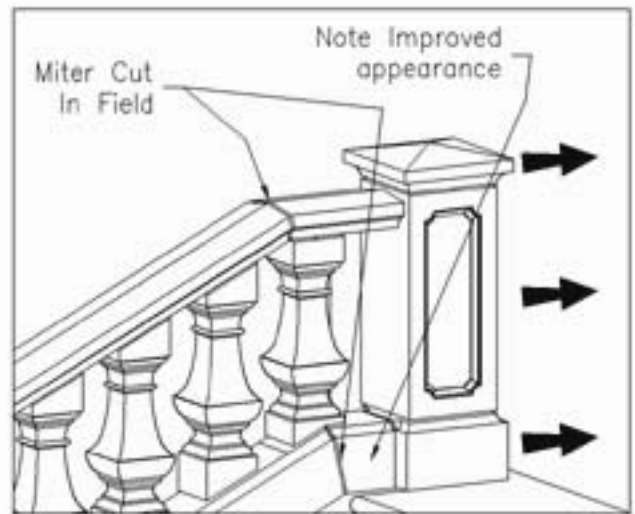

② Mitered Handrail (Newel Pier Moved)  
 Newel Pier Moved to improve appearance

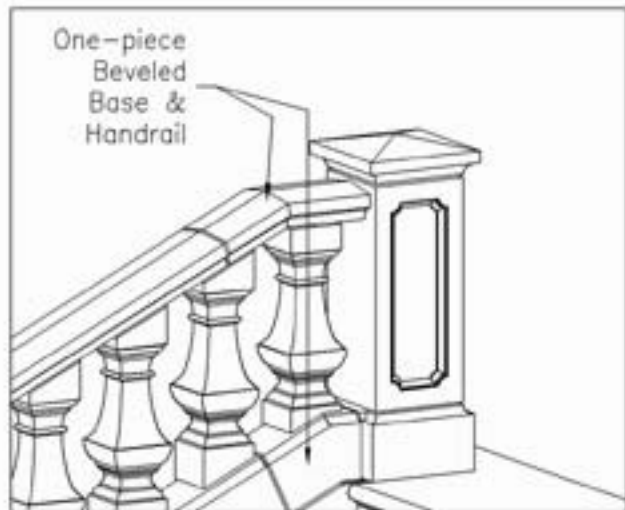

③ Beveled Handrail  
 Provides a cleaner looking transition

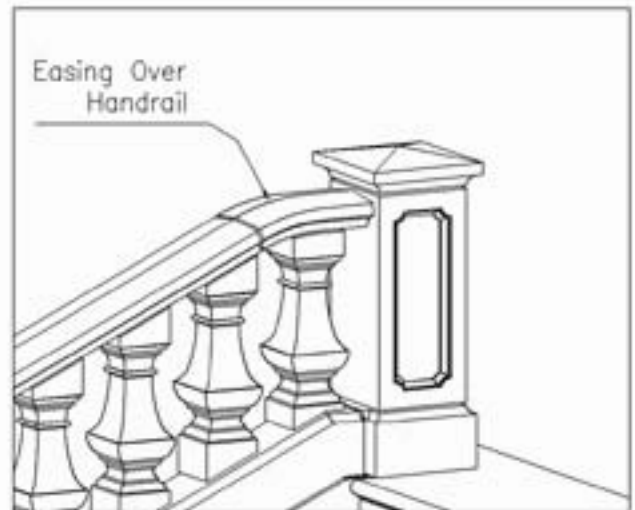

④ Easing Over Handrail  
 Provides an elegant transition

SCALE: NTS.

DEVELOPMENT DRAWING	TITLE: <u>Design Options dwg. Balustrade Top of Stair Handrail</u>
DRAWING DETAIL: MULTIVIEWS	
DESCRIPTION: <u>Balustrades Strair</u>	
NOTES:	
<div style="border: 1px solid black; padding: 5px;"> <ul style="list-style-type: none"> <li><input type="checkbox"/> Type Drawing</li> <li><input checked="" type="checkbox"/> Attachments &amp; Interfaced to: (Type Building)</li> <li><input type="checkbox"/> Design Options</li> <li><input type="checkbox"/> Flashing Details</li> <li><input type="checkbox"/> Cutting &amp; Fitting Details</li> <li><input type="checkbox"/> Building Code</li> <li><input type="checkbox"/> Measuring</li> </ul> </div>	
DATE: 06/23/2003	
DRAWING #: BALDO REV: 1	

**Design Options dwg. Balustrade Handrail Ends:**

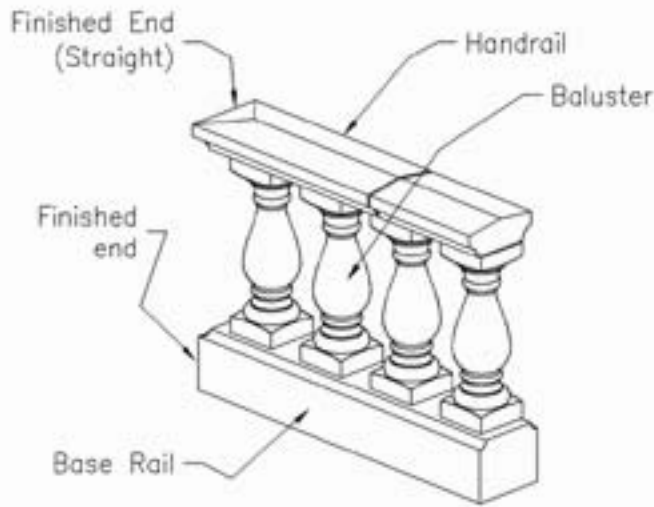

5 Finished End (Straight)

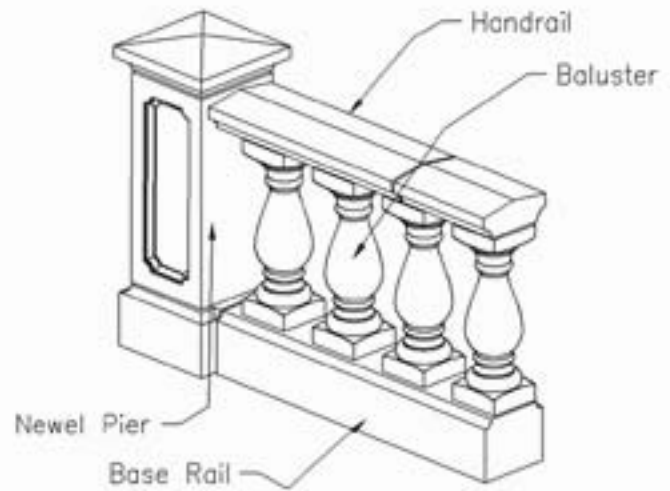

6 End in Newel Pier

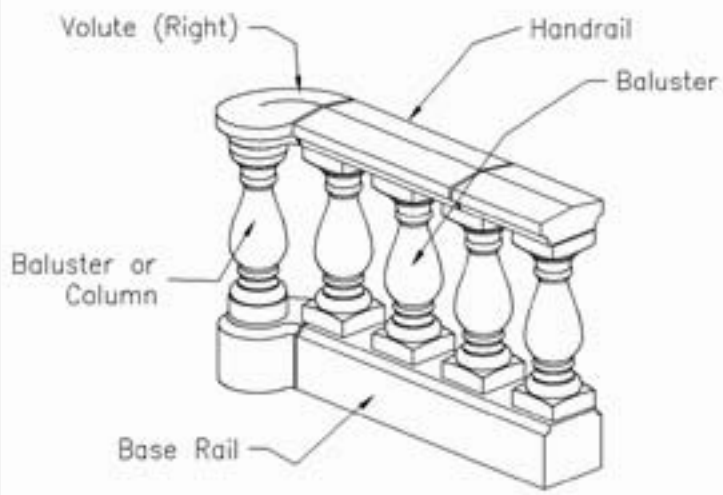

7 Volute End

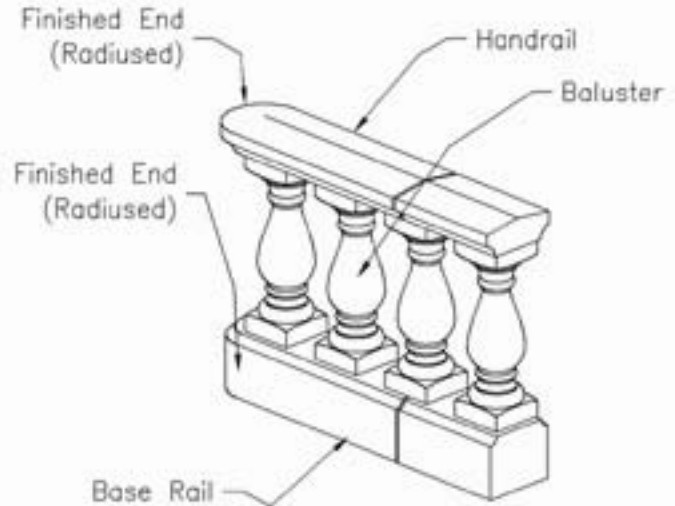

8 Finished End (Radiused)

SCALE: NTS.

DEVELOPMENT DRAWING TITLE: Design Options dwg. Balustrade Handrail Ends:

DRAWING DETAIL: MULTIVIEWS

DESCRIPTION: Balustrades

NOTES:

- Type Drawing
- Attachments & Interfaced to: (Type Building)
- Design Options
- Flashing Details
- Cutting & Fitting Details
- Building Code
- Measuring

DATE: 06/23/2003

DRAWING #: BALDO REV: 1

# Finishing Details dwg. Balustrade Handrail Ends: 2) Miter Cut Details

<input type="checkbox"/>	Type Drawing
<input checked="" type="checkbox"/>	Interface/Attachments
<input checked="" type="checkbox"/>	Finishing Details
<input type="checkbox"/>	Flashing
<input type="checkbox"/>	Cutting Details
<input type="checkbox"/>	Building Code
<input type="checkbox"/>	Measuring & Dimensional Drawings
<input type="checkbox"/>	Attached to type structure

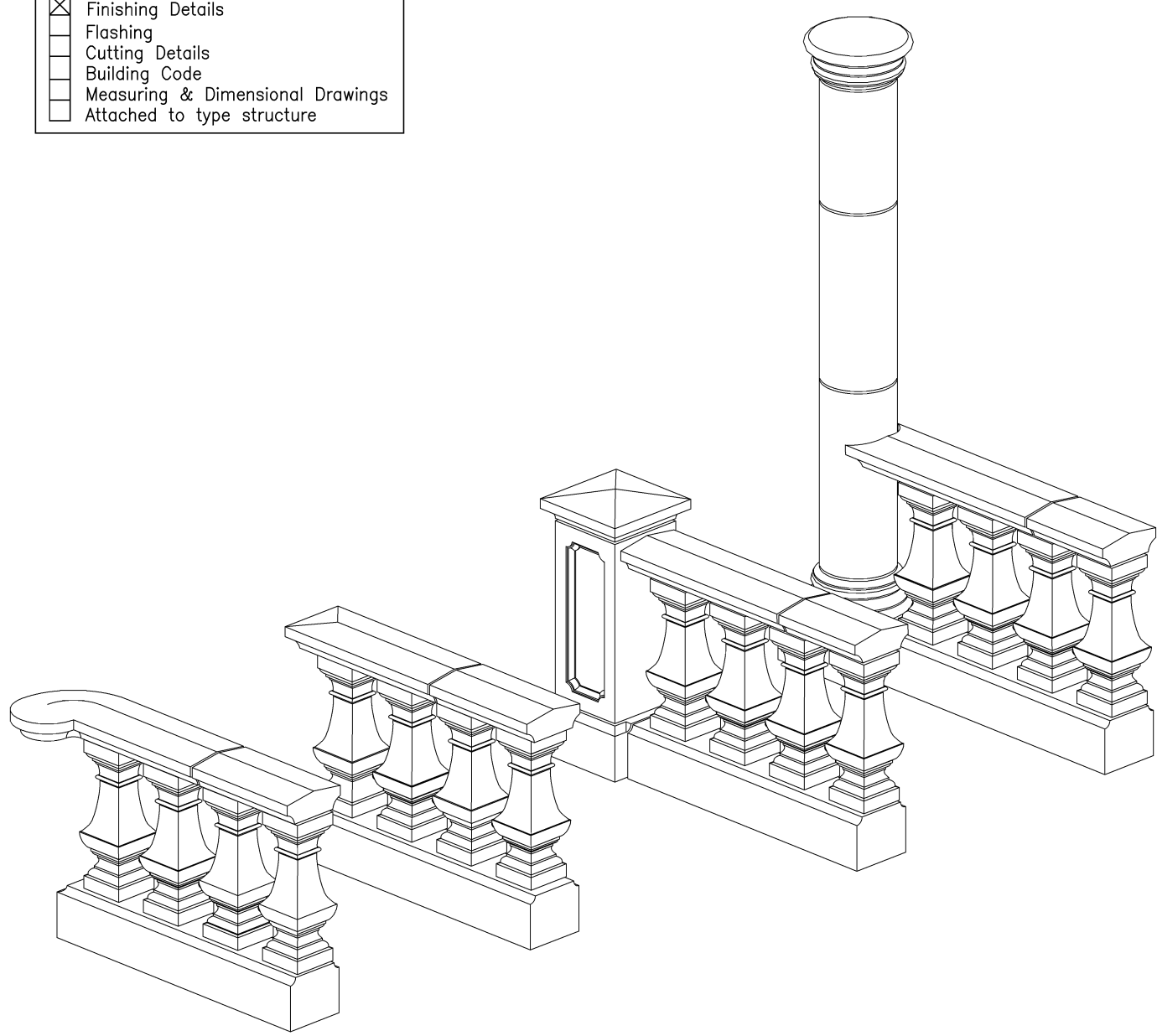

SCALE: NTS.

	<b>DEVELOPMENT DRAWING</b>	TITLE: <u>Cutting Details dwg. Top of Step Handrail:</u>
	DRAWING DETAIL: <b>MULTIVIEWS</b>	
	DESCRIPTION: <b>Steps &amp; Balustrades</b>	
	NOTES:	
		DATE:
		DRAWING #: <b>BALFIN</b> REV:

Design Options dwg. Balustrade Handrail Ends against Columns:

Cut Handrail in Field as shown



Note: If the Handrail is too wide in comparison to the Column Diameter it can weaken the outside corners which can result in cracking.

10 Plan View of Full Radiused End  
Cut to fit in field

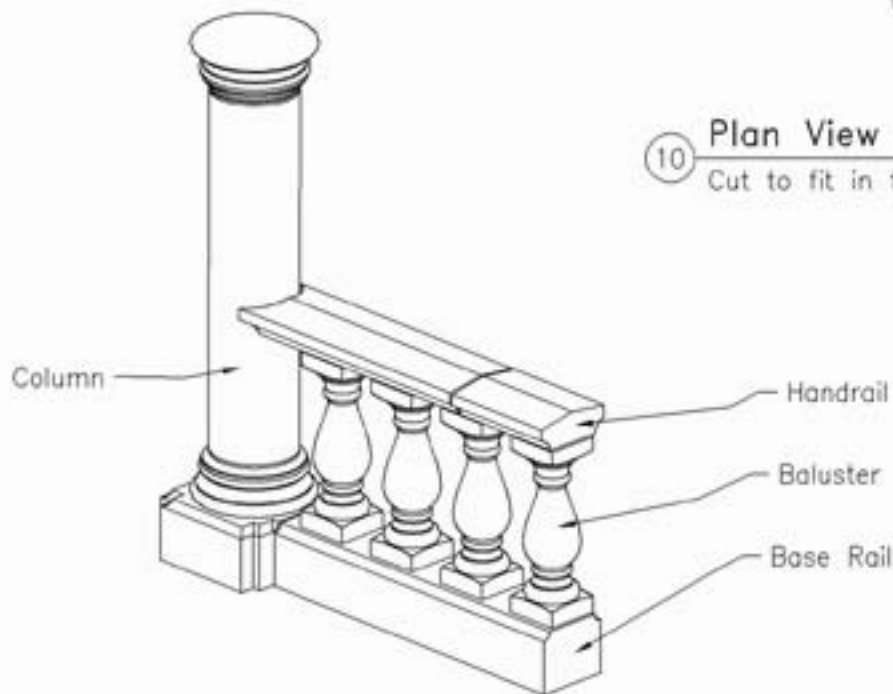

9 Full Radiused end adjacent to Column  
Cut in Field

SCALE: NTS.

DEVELOPMENT DRAWING

TITLE: Design Options dwg. Balustrade Handrail to Columns:

DRAWING DETAIL: MULTIVIEWS

DESCRIPTION: **Balustrades**

NOTES:

<input type="checkbox"/>	Type Drawing
<input checked="" type="checkbox"/>	Attachments & Interfaced to: (Type Building)
<input type="checkbox"/>	Design Options
<input type="checkbox"/>	Flashing Details
<input type="checkbox"/>	Cutting & Fitting Details
<input type="checkbox"/>	Building Code
<input type="checkbox"/>	Measuring

DATE: 06/23/2003

DRAWING #: BALDO REV: 1

Design Options dwg. Balustrade Handrail Ends against Columns:

Cut Handrail in Field as shown

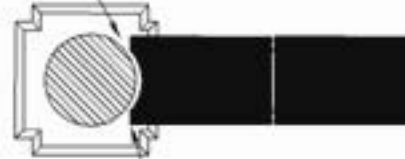

Note: This joining configuration is preferred where the Handrail is wide in comparison to the Column.

**14** Plan View of Finished End (Half Radiused)  
No Cutting required

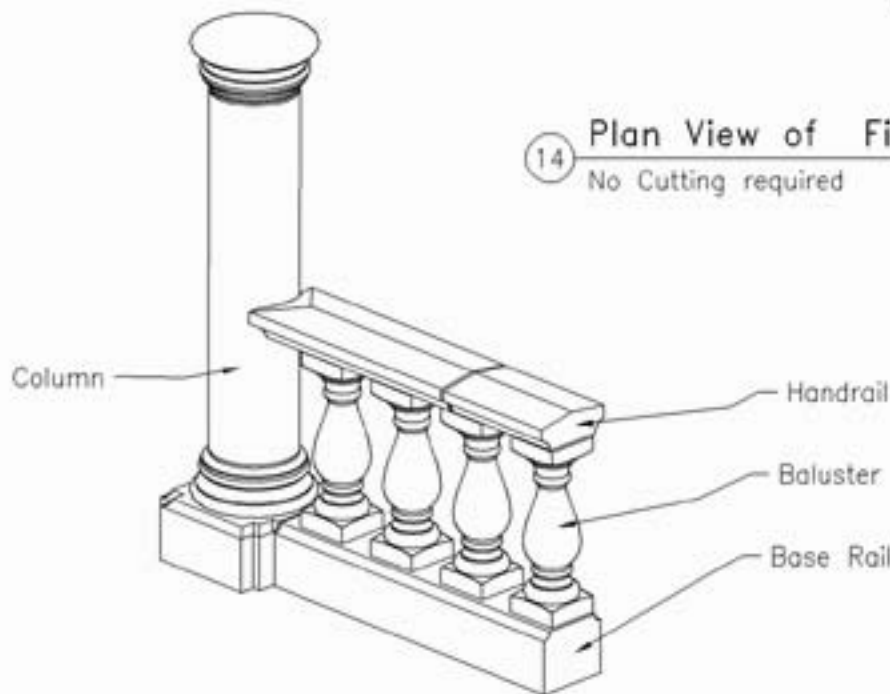

**13** Finished End (Half Radiused) adjacent to Column  
Cut to fit in field

SCALE: NTS.

DEVELOPMENT DRAWING

TITLE: Design Options dwg. Balustrade Handrail to Columns:

DRAWING DETAIL: MULTIVIEWS

DESCRIPTION: **Balustrades**

NOTES:

- Type Drawing
- Attachments & Interfaced to: (Type Building)
- Design Options
- Flashing Details
- Cutting & Fitting Details
- Building Code
- Measuring

DATE: 06/23/2003

DRAWING #: BALDO REV: 1

Design Options dwg. Balustrade Handrail Ends against Columns:

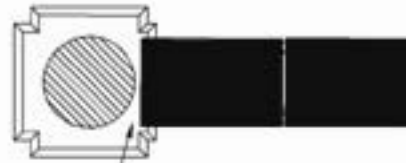

Note: Handrail must clear Column.

12 Plan View of Handrail Finished End  
No Cutting required

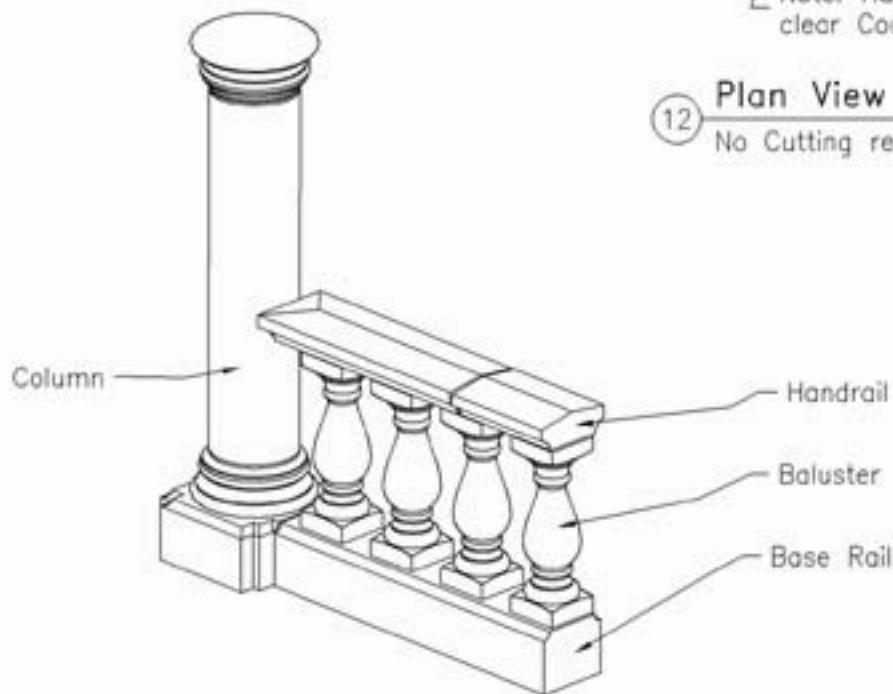

11 Finished End (Straight) adjacent to Column  
No Cutting Required.

SCALE: NTS.

DEVELOPMENT DRAWING

TITLE: Design Options dwg. Balustrade Handrail to Columns:

DRAWING DETAIL: MULTIVIEWS

DESCRIPTION: **Balustrades**

NOTES:

<input type="checkbox"/>	Type Drawing
<input checked="" type="checkbox"/>	Attachments & Interfaced to: (Type Building)
<input type="checkbox"/>	Design Options
<input type="checkbox"/>	Flashing Details
<input type="checkbox"/>	Cutting & Fitting Details
<input type="checkbox"/>	Building Code
<input type="checkbox"/>	Measuring

DATE: 06/23/2003

DRAWING #: BALDO REV: 1