

Entry Legend



Organization Guide

- Type Description
- Primary View
- Surname / Profile
- Dimension

Listed below are available catalog options as shown in this chapter. Refer to page 6 for a complete list of available TypeDescriptions, PrimaryViews and Modifiers.

Product Groups	Type Descriptions	Primary Views	Modifiers
Entries	Entry	CircleTop SquareTop Eyebrow Palladium GothicArch CircleTopTriple EllipticalTop Pediment Portico FullFacade Alcove	Balustrade Bracket CircleTop Column Pilaster Dentil Doublesided Entablature Eyebrow Key Leg Niche Ornament Panel Pediment Quoins Wings

Pricing Legend

Entry costs are calculated based on an **Each Unit Basis**.

Refer to the **Stone Legends Pricing Legend**, located as an insert at the back of the catalog, for more information on calculating stone costs for catalog units.

Drawings occasionally include optional material, or items furnished by others. Adjustments and substitutions are possible in many cases, and are indicated on each entry. Alterations may involve additional charges.

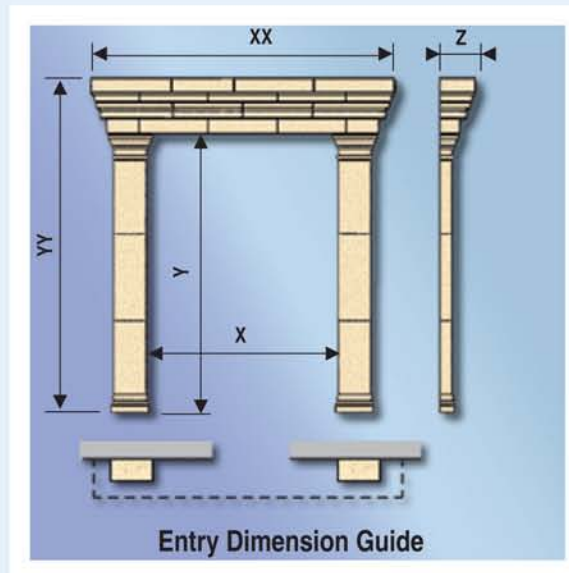

- X** Width of a unit. A control dimension.
- XX** Overall maximum width of a unit.
- Z** Maximum depth of stone in a unit.
- Y** Height of a unit. A control dimension.
- YY** Overall maximum height of a unit.
- R** Radius of a unit.
- B** Rise of an unit. For instance the interior height of an entry that is not a true half circle.

301 Pleasant Drive • Dallas, TX 75217
 (800) 398-1199 • FAX (214) 398-1293
 www.stonelegends.com • sales@stonelegends.com

STONE LEGENDS

Entry Legend



As Rome expanded, embracing the experiences of the Hellenistic world, porticos became a part of the urban landscape.

The technique of building with cast stone was perfected during this period.

Our entries will welcome you and your guests into your home. Their classical designs make them appropriate for any environment. Entries can be as simple or as elaborate as desired and can include columns, pilasters, face stone, profiled surrounds, entablatures, and balustrade.

The choice is yours, to express your taste in your home. This section of the catalog is designed to spark your imagination. You can use any of the existing entries shown on the fol-

lowing pages, combine elements from different entries or have us design something unique to suit you and your project.

Many of the flat entries are great as an interior door units too, single- or double-faced!

Think of this – when someone rings your doorbell, you will want them to be impressed by exceptional quality stone they can see and touch. Add one of our Entry Units to your project now!

Entry Unit Styles

Stone Legends currently offers a wide variety of Entries, in many styles from classical shapes to a more ornate, baroque appearance. A few have optional sizes available and some can be modified in height and/or width to fit your project.

Shown on this chapter are only a few of those currently available, many with actual photos of installed units. The drawings are not to a specific scale.

For ease of use, we have categorized our entries into four styles:

Flat Entry

Entries attached directly to your structure, with minimal projection. They may or may not include door jambs or soffit returns.

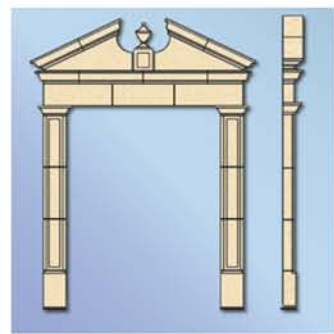

Flat Entry

Recess or Alcove Entry

Entries that stand out from the face of the building, some by as much as 3 feet or more, but are not classified as porticos.

Porch / Portico Entry

Entries that stand out from the face of the

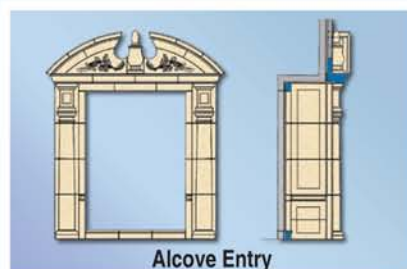

Alcove Entry

building, supporting roofs or balconies.

Full Facade Entry

Entries using stone facing for all or most of the front wall surface area. Since these are highly

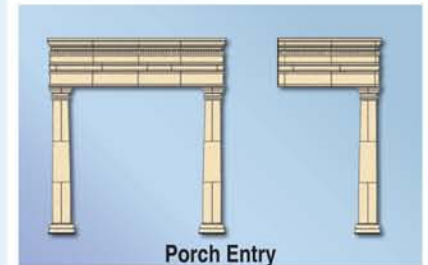

Porch Entry

technical, we recommend contacting us as early in the building design process as possible.



Full Facade Entry

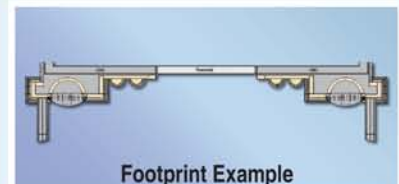

Footprint Example

STONE LEGENDS

301 Pleasant Drive • Dallas, TX 75217
(800) 398-1199 • FAX (214) 398-1293
www.stonelegends.com • sales@stonelegends.com